

## **World Wind Energy Conference & Exhibition WWEC 2007**

**2<sup>nd</sup> to the 4<sup>th</sup> of October 2007  
Mar Del Plata, Argentina.**

Paper to the conference proceedings

### **Capacity Building for Sustainable Energy Access in North Africa Wind Energy as Catalyst for Regional Development**

Khalid Benhamou

Sahara Wind Inc., 32 rue Lalla Meryem Souissi Rabat, 10100 - Morocco

Tackling the global consequences of climate change, environmental degradations and rampant desertification on largely agricultural based societies currently under high demographic pressure is a key social priority, as they generate economic distress leading to mass migration which represents a key challenge for the region's future. Initially encouraged to provide employment in the relatively poor North Sea regions of Germany, the wind energy industry has emerged in the last 10 years, as a major business providing most competitive prices of electricity even when operated under marginal European wind conditions. The trade winds that blow along the Atlantic coast from Morocco to Senegal represent one of the largest and most productive wind potentials available on earth. Because of the erratic nature of winds however, wind energy cannot be integrated locally on any significant scale unless a different, more integrated approach is considered. Having been exposed to extremely weak grid absorption capacities while installing one Africa's first 50kW hybrid wind-diesel system in 1995, and because of the extremely limited and decentralized grids of the countries located in the Saharan region (120 MW on average), the author of this paper is engaged in a broad ranging bottom-up capacity building strategy. The aim of this strategy is to provide or improve local energy access solutions relying on the region's knowledge centers, universities, local business and a vibrant will from the region's decisions makers to address the global challenges that nature has imposed upon them. While in its initial implementation phase this program is gaining momentum as it highlights the possibilities for synergies that a technology such as wind energy can provide when integrated and picked up by local industries. Initiated by Sahara Wind Inc. a company from the private sector, these associated project development activities sponsored by several multilateral institutions serve as the foundation of an ambitious program supporting a vision highlighting possibilities for tackling energy scarcity and sustainable development objectives on a regional basis through local synergies. The reliance on the ability of public bodies such as universities and other public institutions to concretize dynamic partnerships with the local private sector and industries in order to develop strategies aimed at improving energy access issues is key to the success of this program. This combination is likely to take advantage of the significant breakthroughs expected to happen in the near future regarding newer energy technologies and their association with large, untapped sources of renewable energies. Building up capacities by enabling academia to train technicians and engineers to become familiar with these technologies would represent a significant investment into the future. As a domestic resource, the harnessing of renewable energies could indeed reinforce the role of local universities and applied research institutions to address an underlying brain drain issue that is also affecting these regions.

**Key words:** trade winds, intermittent storage, grid stability, alternating current, high wind penetration, distributed, grid infrastructure, capacity building, synergies, pilot/demonstration project, applied research, Sahara, desertification, energy access, Morocco, Mauritania, carbon-free, wind-electrolysis, hydrogen, new energy technologies.

## **1. Energy supply, energy access a development imperative**

Tackling the global consequences of climate change, environmental degradations and rampant desertification on largely agricultural based societies currently under high demographic pressure is a key social priority, as they do generate economic distress leading to mass migration. Being net exporters of immigrants, Morocco and Mauritania are located on the main routes of migrant populations from Sub-Saharan Africa which together, constitutes a significant security threat to the stability of the region and that of NATO countries. Within such context, granting basic access to energy services such as electricity is essential to develop local, sustainable economic activities capable of preventing and fixing migrant populations.

With a 96% energy dependency from fossil fuel imports absorbing most of Morocco's export revenues, the impact of such dependency on budgetary spending is quite significant. Since over 30% of National budgets are dedicated to education in the region, one can easily understand how critical the development of sustainable energy consumption schemes can be. While Mauritania enjoys a slightly improved situation regarding its energy dependency, its scarce population is distributed over a vast territory in which access to electricity is virtually impossible to grant through conventional grid infrastructures.

## **2. Wind power, a social energy economy**

Initially encouraged to provide employment in the relatively poor North Sea regions of Germany, the wind energy industry has emerged in the last 10 years, as a major business providing the most competitive prices of electricity even when operated under marginal European wind conditions. The trade winds that blow along the Atlantic coast from Morocco to Senegal represent the largest and most productive wind potential available on earth. Because of the erratic nature of winds however, wind energy cannot be integrated locally on any significant scale unless a coordinated research is initiated towards far ranging, more advanced energy alternatives. As both countries dispose of this vast wind energy source, and as they face similar social pressure from domestic and sub-Saharan migrant populations fleeing deteriorating environmental conditions, fostering collaboration on applied research in clean and more sustainable energy technologies for tackling energy access on a regional base seems quite relevant.

Collaboration between Morocco and Mauritania's educational and scientific communities could provide focus and a broader sensitization effect on the development of local technical alternatives that can address the economic consequences of high energy dependencies or limited energy accesses. Both countries dispose of skilled human capacities and scientist pools that would gain significantly in coordinating such research programs as their respective energy challenges are quite complementary. Building regional scientific capacities, and developing a common vision that can generate economic growth in integrating an environmentally friendly and sustainable energy industry (wind energy has 25% growth rates worldwide focused essentially in Europe) could in the long term, become an alternative in fixing migrant population, and contribute to their social integration.

Introducing newer energy technologies will bring North Africa's scientific communities to take a comprehensive look at energy systems and adopt a holistic, integrated approach to local energy challenges which are linked to development issues that have been driven thus far mostly by external market forces providing unsuited ready made solutions. Indeed, experiences in North Africa have clearly shown that efforts aimed at introducing (new) wind energy technologies in these developing countries amounts ultimately to the simple export of turn key equipments supported by concessionary sources of financing and export credit packages. These policies have done very little in terms of local impact for a technology that

could have been promising in terms of economic returns, in addressing energy access, energy security, and the creation of an accessible integrated industrial activity.

**3. Wind power and electric grid saturation:**

The saturation of the African continent’s largest electricity grids to further wind developments due to grid stability problems will quickly highlight the need to develop a more comprehensive and integrated approach. While relying on a highly interconnected grid, Denmark, the world wind energy leader has not managed to cover more than 25% of its domestic energy consumption through wind before encountering major grid stability problems. The country has frozen its wind development activity for the last two years although Wind turbine manufacturing remains Denmark’s main industrial employer. The export of expensive European made wind turbines to lucrative markets (such as in the USA) is not meant to provide a solution to Africa’s electricity access challenges. Although 25% of Denmark’s domestic electricity consumption may be quite significant, the same proportion (if achievable...) in the Saharan or Sub-Saharan context will translate into very little quantities of wind turbines installed. Limited numbers of large wind turbines and their remoteness will make maintenance issues extremely difficult to handle. Indeed, with about 120 MW of total installed capacities, decentralized and distributed over territories that are twice the size of France, countries like Mauritania, Mali, Niger and Chad to name a few, will hardly make it possible for any conventional wind energy technology to become commercially viable. Developing alternative wind energy technologies to feed smaller electricity markets could be essential for tackling the region’s decentralized energy access issues and enable the development of a local, viable wind energy industry which could be essential for tackling the regions economic challenges currently under pressure from Sub-Saharan migrant populations.

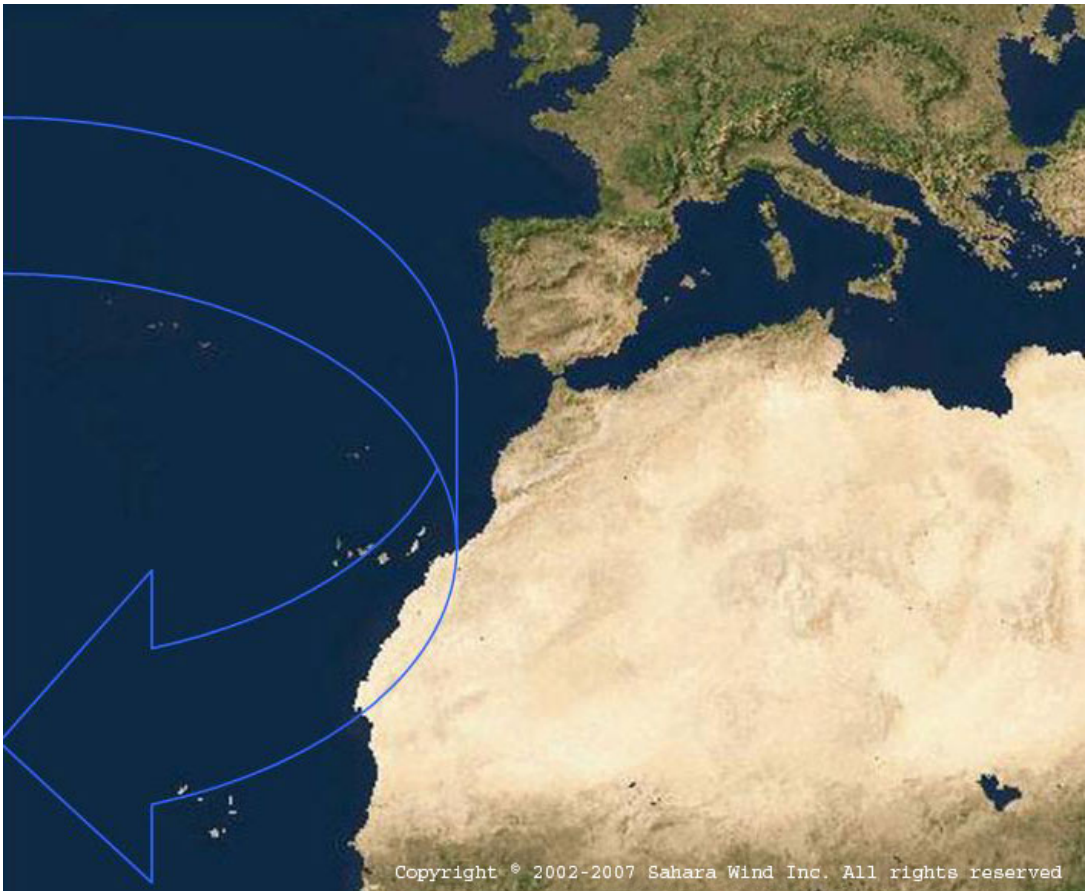

**Figure 1:** A vast renewable resource potential: global Trade Winds over North West Africa

Since this region is located on the edge of one of the largest electricity grids (EU grid), its large renewable energy potential could be used to produce significant amounts of cheap wind

energy that could ultimately end up supplying larger electricity markets. This however, will require an effect of scale. Developing mechanisms to initially firm this energy locally is very important as it lies in the critical path of major alternative, sustainable energy developments.

#### **4. Hydrogen for environmentally friendly, sustainable energy production**

It is important to mention that current alternatives of hydrogen production through natural gas reforming processes represent today over 95% of the world's hydrogen production, which without any sequestration technologies emits 6 tons of CO<sub>2</sub> per ton of hydrogen in the process. The production of hydrogen through Wind-electrolysis is carbon free as this process can be duplicated over a very large scale in Morocco and Mauritania's trade wind regions. In generating both electricity and hydrogen at competitive costs and without CO<sub>2</sub> emissions significant environmental security concerns can be addressed. As natural gas supply disruptions to NATO countries have recently highlighted, the dependency on a single source of energy relying on fixed infrastructures that required hefty investments is a highly sensitive matter. Taping on such natural gas resources to produce hydrogen, would strain these issues even further. Thus the need to diversify the production of hydrogen away from natural gas, whose demand is likely to grow even further, is of paramount importance to the collective energy security of all NATO countries.

The production of hydrogen through wind-electrolysis is carbon free as this process generating both electricity and hydrogen can be duplicated over a very large scale in Morocco and Mauritania's trade wind regions. In providing large amounts of electricity and hydrogen at competitive costs -without CO<sub>2</sub> emissions- significant environmental security concerns can be addressed. The advent of a carbon free hydrogen economy provides an entirely new environmental dimension that is sustainable in terms of resources. Hydrogen provides a valorization of renewable energies that relying on sound economics based on capacity building and local value added processing industries.

#### **5. Current energy economics versus newer energy alternatives**

The global competition for fossil fuel supplies has created an oil and gas frenzy which generated hefty oil and gas revenues for oil producing countries that often times cannot integrate these incomes into their own economies. Since prices keep-on soaring, this has created the perverse effect of discouraging oil suppliers to expand further their hydrocarbon potential, offsetting critical investments needed to keep up with high demand. Under the same token, long term gas deliveries and contracts are also being disrupted, leaving energy transit and consuming nation with very little room to maneuver or renegotiate.

The advent of a carbon free hydrogen economy provides an entirely new economic dimension into the energy debate as the resource is renewable, hence non-speculative, and provides significant local capacity building advantages. The social dimension of such a new energy economy underlines a fundamental energy security issue for NATO countries as it opens much needed energy diversification perspectives and alternatives from the current natural gas resources and infrastructure paradigm. Recent energy security propositions triggered for that matter, an almost existential debate on the role and functioning of the alliance during the recent NATO summit in Riga. Seen the conjuncture, these issues are likely to be further exacerbated in the future.

Upstream project development activities relative to the Sahara Wind Energy Development Project made it relevant to establish these carbon free hydrogen production perspectives, in encouraging countries with similar potentials to collaborate and exchange expertise, through excellence centers located in their universities. It may be sensible to mention that wind-electrolysis for grid stabilization, hydrogen production and energy storage enables an integration of wind energy systems within weak grids through small, medium and large integrated applications.

Initiated by Sahara Wind Inc. the NATO Science for Peace SfP-982620 project intends to support a comprehensive strategy aimed at fostering an effective and integrated wind resource utilization through development programs within weak grid infrastructures to try and tackle both the social causality (energy access) and the effects of illegal immigration issues through synergies and the creation of local wind energy industries. In developing a bottom-up regionally integrated capacity building process through an effectual collaboration between Morocco and Mauritania's main scientific communities, this project aims at addressing energy access issues, utilizing tools and resources mobilized within an integrated energy strategy to support a long term vision. The region disposes of a qualified pool of university professors, engineers and scientists that are well networked but currently lack appropriately equipped research infrastructures.

Being located on the edge of the world's largest desert, Morocco and Mauritania's largely agricultural based societies are most exposed to global environmental challenges that induces land degradation and desertification which combined with demographic pressure on their largely agricultural based societies tends to generate economic distress. Even if Mauritania has recently discovered an Oil field off-shore (1000 meters below sea level), the production of the offshore platform has proven so far to be below expectation, as a single well is producing less than 30.000 Barrel per Day instead of the initial forecasted 200.000 Barrels per Day. Even so, these rather limited oil sources found in Mauritania do not appear to be sustainable in the long term. For that matter, the policy of the government is precisely to invest these revenues into education and other long term value added sectors. The renewable wind energy source is much more appealing because it is widely available, evenly distributed whether solar or wind energy and can enhance the country's energy access problematic in a significant way.

Cooperation between Morocco and Mauritania in renewable energy technologies is bound to become successful as both countries dispose of a widely untapped wind energy potential with similar difficulties to address for harnessing them. The problematic of renewable energy uptake maximization within weak grid infrastructures is predominant in both Morocco and Mauritania. Developing an upstream strategy within education centers could be essential in building capacities to handle such technical challenges. Emulation between both countries is possible where research institution and different human resource potentials can be mobilized. Morocco disposes of a larger scientific community than Mauritania, however many of the countries challenges in rural electrification are effectively not being addressed by academia, but rather by utilities or agencies that do not conduct research programs. Through the NATO SfP-982620 project, scientific research and educational institutions of the region have the possibility to initiate a comprehensive bottom-up sustainable energy applied research program further into hydrogen production in order to integrate it within their country's main industrial activities.

#### **6. Improved energy access, communications and security:**

Although energy access, security and basic services remain a fundamental responsibility of authorities and governments in these regions, it is important to mention that least cost solutions and adequate support systems have to be provided for local populations that are distributed over vast areas. Conducting applied research within Morocco and Mauritania's research institutions with the involvement of local industries is critical in initiating synergies among developing countries as they face common security threats in loosely controlled remote areas. Areas of great economic importance are lost due to security considerations, particularly in the Sahel region where states rarely dispose of material means to secure their vast territories. It is therefore important that local scientific communities integrate the security costs that the lack of alternatives represents to their own economies.

Energy access solutions and applications are indeed relevant to communication infrastructures and permanent power supply systems in remote sites. Mobile phone networks and basic

security infrastructures do rely heavily on permanent power systems that have to be deployed within broad areas. The development of these infrastructure services and systems enhance the prevention of security related problems which ultimately falls in the responsibility of sovereign states and governments. Indeed, in the Sahara desert, Mauritania is twice the size of a country like France as are Mali, Niger, Chad and other Saharan countries further to the east. This makes any logistics very challenging to deploy through most conventional means. Utilizing wind or any other intermittent renewable energy source to generate fuels in the form of hydrogen that can power everything from electronics to life support systems or even vehicles can open promising endogenous distributed fuel and power generation possibilities in the future.

Mobilizing academia in fulfilling these objectives may be appropriate, since complex hydrogen energy and hydrogen related technologies are likely to have a great importance in the future. Providing access in exposing researchers, Engineers and PhD students to these technologies may open a realm of opportunities for them, as well as for their countries. Besides preventing any technological gaps to widen in time, fields of specialization and excellence can be developed regionally, provided a targeted support and appropriate focus can be put on such installations.

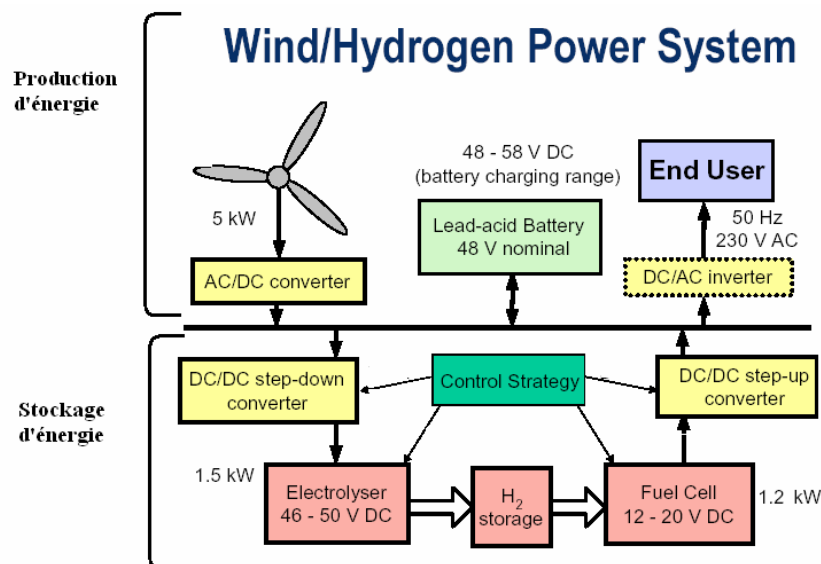

**Figure 2:** Example of a Wind hydrogen fuel cell test bench configuration (NATO SfP-982620)

The NATO SfP-982620 project makes it relevant to develop carbon free hydrogen production perspectives, in encouraging countries with similar potentials to collaborate and exchange expertise, through excellence centers located in their universities. The region disposes of a qualified pool of university professors, engineers and scientists that is well networked but nevertheless lacks appropriately equipped research infrastructures. As most of the NATO SfP budget is dedicated towards co-development and the building of prototypes, this project will enable Morocco and Mauritania’s main scientific communities to dispose of research hardware and develop applied research topics recognized to be on the very edge of what's being done worldwide. In co-developing solutions alike a variety of other prestigious institutions are (alike NREL<sup>1</sup> in the USA, or CEA<sup>2</sup> in France) researchers originally from Morocco and Mauritania located abroad (mainly in NATO countries), will be keen on collaborating within such platforms relevant to their home country’s challenges. While their motivations are high, the tremendous networking potential of ‘African expatriated scientists’ will likely alleviate a rather resentful brain drain issue that currently affects most scientific communities in sub Saharan Africa.

<sup>1</sup> NREL: National Renewable Energy Laboratory, 1617 Cole Blvd., Golden,. CO 80401, USA

<sup>2</sup> CEA: Commissariat à l’Energie Atomique, 25 rue Leblanc, Paris France

The fact that this project is the North Atlantic Treaty Organization's first Science for Peace project in the region is quite indicative on how essential energy access, energy security, capacity building, science and sustainable development have become.